

# Express XT

## Simple Fully Automatic Watermaker

From 200 to 800 gallons per day  
(755 - 3,030 liters per day)



COMPACT



MODULAR

The Blue Water EXPRESS XT watermakers feature fully automatic operation with capacities of up to 33 gallons per hour (126 liters per hour). These units were designed to fit into the tight spaces of small and mid-sized yachts. The one touch operation makes the EXPRESS XT series ideal for applications where it is difficult to access the watermaker while the vessel is underway. The Express XT series includes an automatic Fresh Water Flush system as standard.

### Express XT Systems Feature:

- Full Automatic Operation
- Fresh Water Flush system
- High Rejection membranes
- Product water Carbon filter
- Dual voltage 50/60 Hz motors
- Stainless steel booster pump shaft
- Designed for ease of service and maintenance
- Installation kit including bronze sea strainer
- No charge upgrade to Commercial Pre-filter

### Express XT System Advantages:

- One-touch operation
- Simple controller with LED indicators
- Optional remote control
- Low pressure safety switch
- High Pressure monel transducer
- Available in both compact frame and modular component style configurations
- Adjustable FWF interval up to 10 days

## EXPRESS XT SPECIFICATIONS

Model #	Production / hour	Production / 24 hour	Weight (lbs. / kg.)
EX XT 200	8 Gal / 30 L	200 Gal / 755 L	85 / 39
EX XT 360	15 Gal / 57 L	360 Gal / 1,360 L	90 / 41
EX XT 600	25 Gal / 95 L	600 Gal / 2,270 L	110 / 50
EX XT 800	33 Gal / 126 L	800 Gal / 3,030 L	115 / 52

Model #	Feed Flow GPM	Booster Pump HP   KW	HP Pump HP   KW	Run Amps 110 / 220	Start Amps 110 / 220
EX XT 200	0.5	0.5   0.37	0.5   0.37	7 / 3.5	56 / 28
EX XT 360	1.5	0.5   0.37	1   0.74	13 / 6.5	72 / 36
EX XT 600	3.0	0.5   0.37	2   1.47	26 / 13	94 / 47
EX XT 800	3.0	0.5   0.37	2   1.47	26 / 13	94 / 47

# EXPRESS / EXPRESS XT DIMENSIONS

## COMPACT

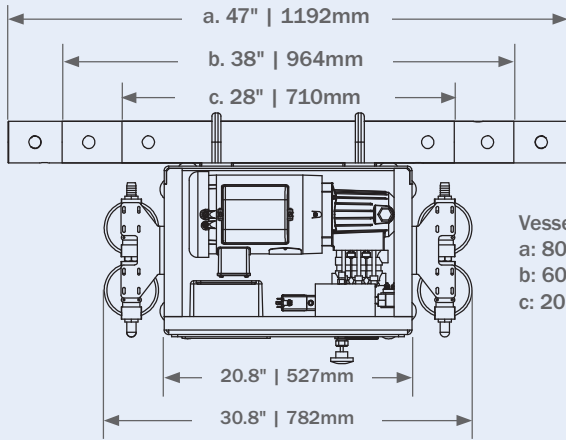

Top View

Vessel Assembly  
 a: 800 GPD  
 b: 600 GPD  
 c: 200 GPD / 360 GPD

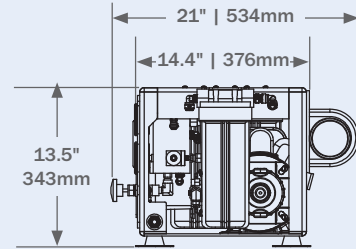

Right Side View

## MODULAR

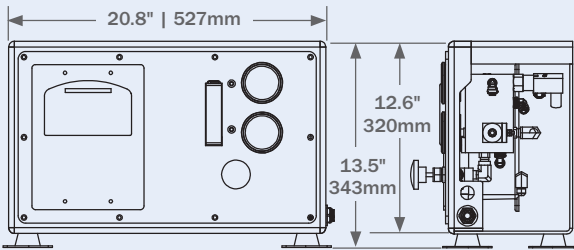

Main Control Panel

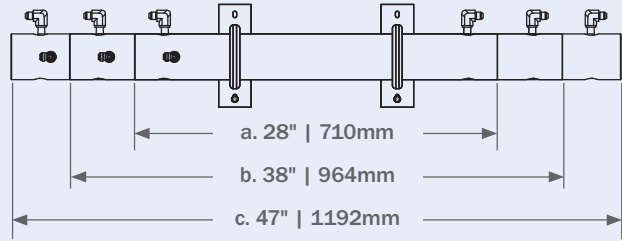

Vessels Assembly - a: 360 GPD | b: 600 GPD | c: 800 GPD

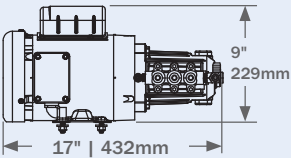

HP Pump (200 & 360)

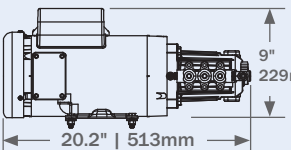
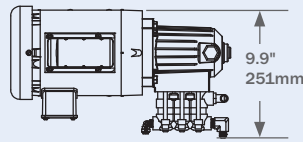

HP Pump (600 & 800)

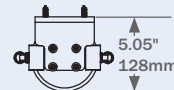
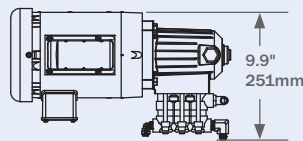

Carbon Filter

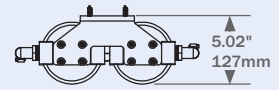
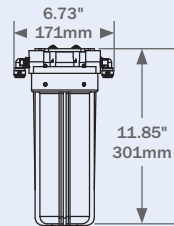

Dual Pre-Filter

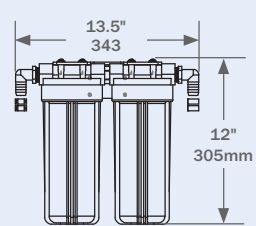

## Components - Compact & Modular

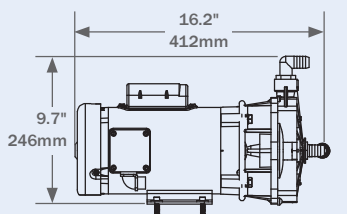

Booster Pump

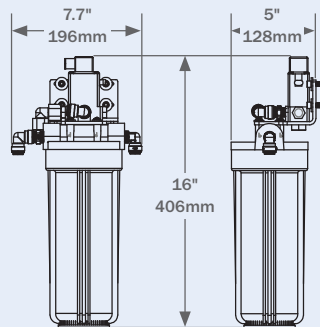
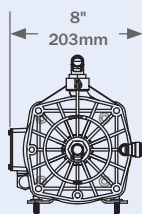

Fresh Water Flush

Optional

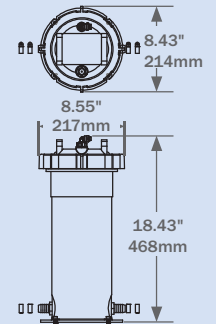

Commercial Pre-Filter /  
OW Separator