

Sewage Water Treatment System

Het Ecomar systeem behandelt volledig automatisch grijs- en zwart water conform de internationaal gestelde eisen zodat het direct over boord gepompt kan worden.

Aan het einde van elke cyclus wordt de ECOMAR unit gespoeld met zeewater, waarna deze weer schoongespoeld klaar staat voor de volgende cyclus.

Het Ecomar systeem kan geschikt worden gemaakt voor het gebruik van **twee** afvalwater tanks, informatie op aanvraag.

Voordelen:

- **Geen sludgetank** benodigd, alle sewage gaat overboord
- **volledig automatisch**, met de mogelijkheid tot handmatige bediening indien nodig
- **compact**: ontworpen voor kleine machine kamers
- **geen verontreiniging**, het desinfectiemiddel wordt volledig afgebroken gedurende het reinigings-proces.



ECOMAR unit

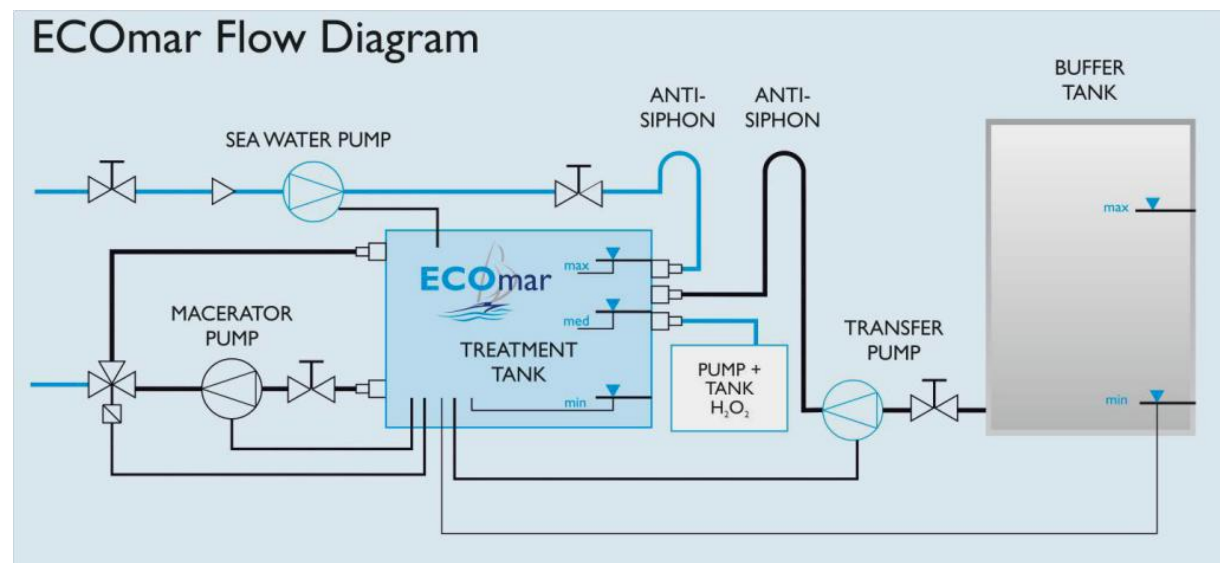



zeewaterpomp



sewage transport pump



doseer installatie

system specificaties

	ECOMAR 545	ECOMAR 340	ECOMAR 145	ECOMAR 70	ECOMAR 45	ECOMAR 32	ECOMAR 20
Max treatment capacity (litres/day)	54500	34000	14500	7000	4500	3200	2000
Work cycles per hour (approx.)	3	3	3	3	3	3	3
Power supply	230 / 400 V a.c.	230 / 400 V a.c.	230 / 400 V a.c.	230 / 400 V a.c.	230 / 400 V a.c.	230 / 400 V a.c.	230 / 400 V a.c.
Installed power (kW) at 230 V a.c.			1.1	1.1	1.1	0.75	0.75
at 400 V a.c.	11	5.5	1.5	1.5	1.5	0.75	0.75
Max absorption (A)	20	12	4.5 (400 V a.c.) / 7 (230 V a.c.)			2 (400 V a.c.) / 4 (230 V a.c.)	

Dimensions and weight

Central unit dimensions (mm)	1970x1700 x1375	1390x1100x1350	1230x820x810	930x670x710	770x590x710	730x510x690	500x500x690
Tank dimensions (mm)	1785x995x1205	1300x850x1200	1150x600x700	850x470x620	710x390x650	660x320x600	450x300x600
Central unit weight (kg)	Inox PP	915 450	190	112	100 70	46 40	35 30
Persons if passenger ships* (without vacuum system - 230 l/day)	236	147	63	30	19	14	8
Persons if passenger ships* (with vacuum system - 185 l/day)	294	183	78	37	24	17	10
Persons if other ships* (without vacuum system - 180 l/day)	302	188	80	38	25	17	11
Persons if other ships* (with vacuum system - 135 l/day)	403	251	107	51	33	23	14

* at peak treatment capacity per day



Lloyd's
Register

CERTIFIED BY LLOYD'S REGISTER ACCORDING TO THE RESOLUTION MEPC 227 (64) AND EUROPEAN DIRECTIVES (MED) 96/98/EC AND SUBSEQUENT AMENDMENTS.

U.S. COAST GUARD CERTIFIED

